



Catálogo de Productos

Pressure reducing valve, direct operated, sandwich plate,
type ZDR6D...40B/(New Series)

Size 6

up to 21 MPa

up to 50L/min

Features:

- Sandwich plate design
- 4 pressure ratings
- 3 adjustment elements:
 - Rotary knob
 - Sleeve with hexagon and protective cap
 - Lockable rotary knob with scale
- Pressure reduction in ports A, B or P
- Check valve, optional
- Porting pattern to DIN 24 340, form A,ISO 4401 and CETOP-RP 121H

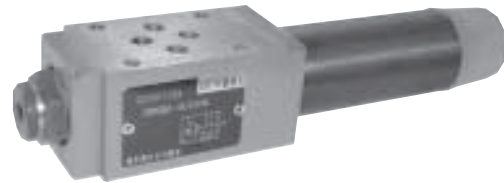

Functional, section

Pressure reducing valves type ZDR 6 D.. are 3-way direct operated pressure reducing valves of sandwich plate design with a pressure relief function on the secondary side. It is used to reduce the system pressure. The pressure reducing valve basically consists of the housing (1), the control spool (2), a compression spring (3) and the adjustment element (4) as well as with an optional check valve.

The secondary pressure is set by the pressure adjustment element (4).

Model "ZDR6DA"

At rest, the valve is normally open, and fluid can flow unhindered from port A to port A1. The pressure in port A1 is at the same time via the control line present at the spool area opposite to the compression spring (3). When the pressure in port A1 exceeds the pressure level set at the compression spring (3) the control spool (2) moves into the control position against the compression spring (3) and holds the set pressure in port A1 constant.

The control pressure and pilot oil are taken from port A1 via control line.

If the pressure in port A1 rises still further due to external forces, the control spool (2) is moved still further towards the compression spring (3).

This causes a flow path to be opened at port A1 through control land (9) on the control spool (2) to tank. Sufficient fluid then flows to tank to prevent any further rise in pressure. The spring chamber (7) is always drained to tank externally via drilling (6) to port T (Y).

A pressure gauge connection (8) permits the secondary pressure at the valve to be monitored.

It is only possible to fit a check valve for free flow in ports A1 to A in version "DA".

Models "DP" and "DB"

In model "DP", the pressure is reduced in port P1. The control pressure and the pilot oil is taken internally from port P1.

In model "DB", the pressure in port P1 is reduced, and the pilot oil taken from port B.

Attention!

In model DB, it must be ensured, that the pressure in port B is not higher than the set pressure when the directional valve is in position P to A. Otherwise, pressure in port A will be reduced.

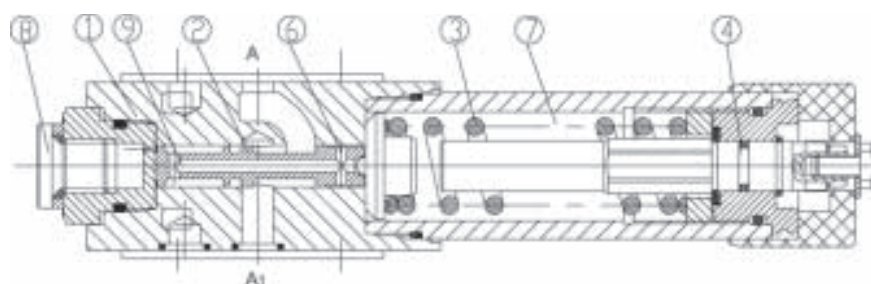

Type ZDR6DA1-40B/...YM...

Symbols (① =valve side, ② =subplate side)

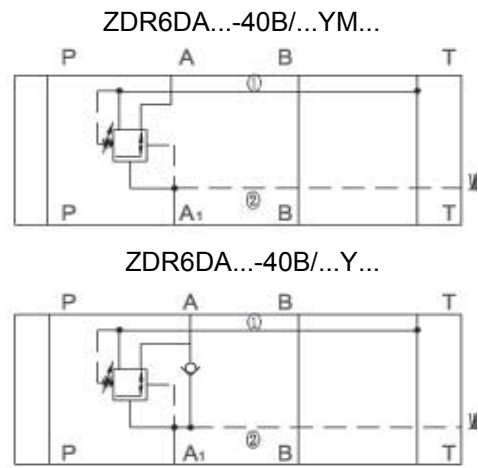
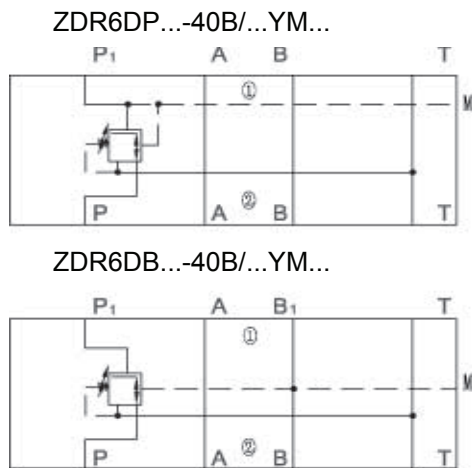

Ordering details

Z	DR	6	D		- 40	B	/	Y		*
Sandwich plate design = Z	Pressure redcing valve = DR	Nominal Size 6 = 6	Direct operated = D	Pressure reduction in port A = A Pressure reduction in port B = B (Pilot oil from port B) Pressure reduction in port P = P						Further details in clear text No code. = mineral oils V = phosphate ester No code. = with check valve (only possible for pressure reduction in port A) M = without check valve Y= Pilot oil feed internal, drain external 25= max. secondary pressure 2.5 MPa 75= max. secondary pressure 7.5 MPa 150= max. secondary pressure 15 MPa 210= max. secondary pressure 21 MPa
Adjustment element Rotary knob = 1 Hex. head screw with protective cap = 2 Lockable rotary knob with scale = 3										
Series 40 to 49 = 40 (40 to 49 = unchanged installation and connection dimensions)										B= Technology of Beijing Huade Hydraulic

Technical data (For applications outside these paramters, please consult us!)

Pressure fluid		Mineral oil (for NBR seal) or phosphate ester (for FPM seal)
Pressure fluid-temperature range	(°C)	-30 to +80
Viscosity range	(mm ² /s)	10 to 800
Degree of fluid contamination	(µm)	Maximum permissible degree of contamination of the fluid is to NAS 1638, class 9. β ₁₀ ≥ 75
Max. operating Pressure (inlet)	(MPa)	up to 31.5
Secondary pressure (output)	(MPa)	up to 2.5, up to 7.5, up to 15.0, up to 21.0
Back pressure port	(MPa)	up to 16.0
max. flow	(L/min)	up to 50.0
weight	(kg)	approx. 1.2

Characteristic curves (measured at $v = 41 \text{ mm}^2/\text{s}$ and $t = 50^\circ\text{C}$)

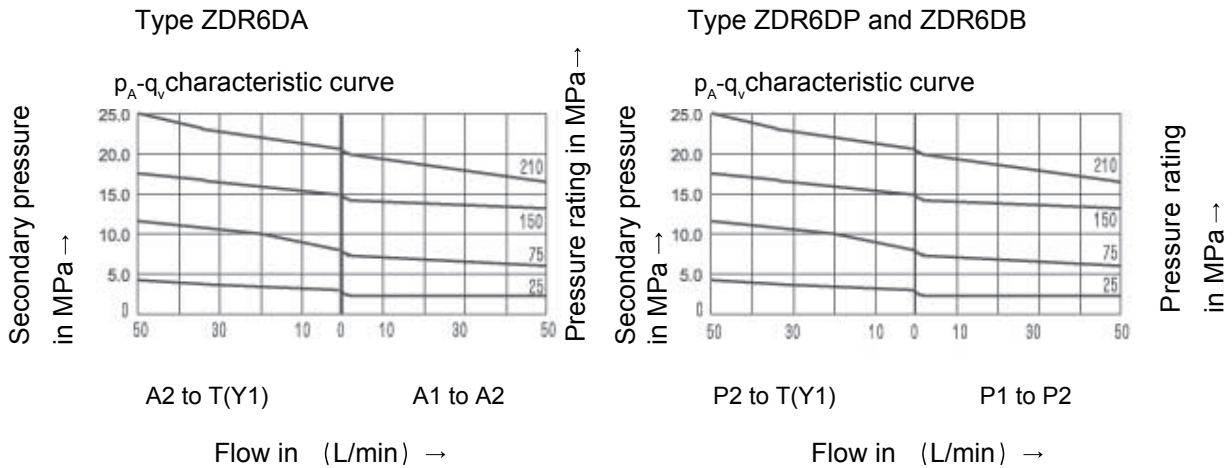

Note:

The curve characteristics remain, with low set pressures, the same in relation to the pressure rating

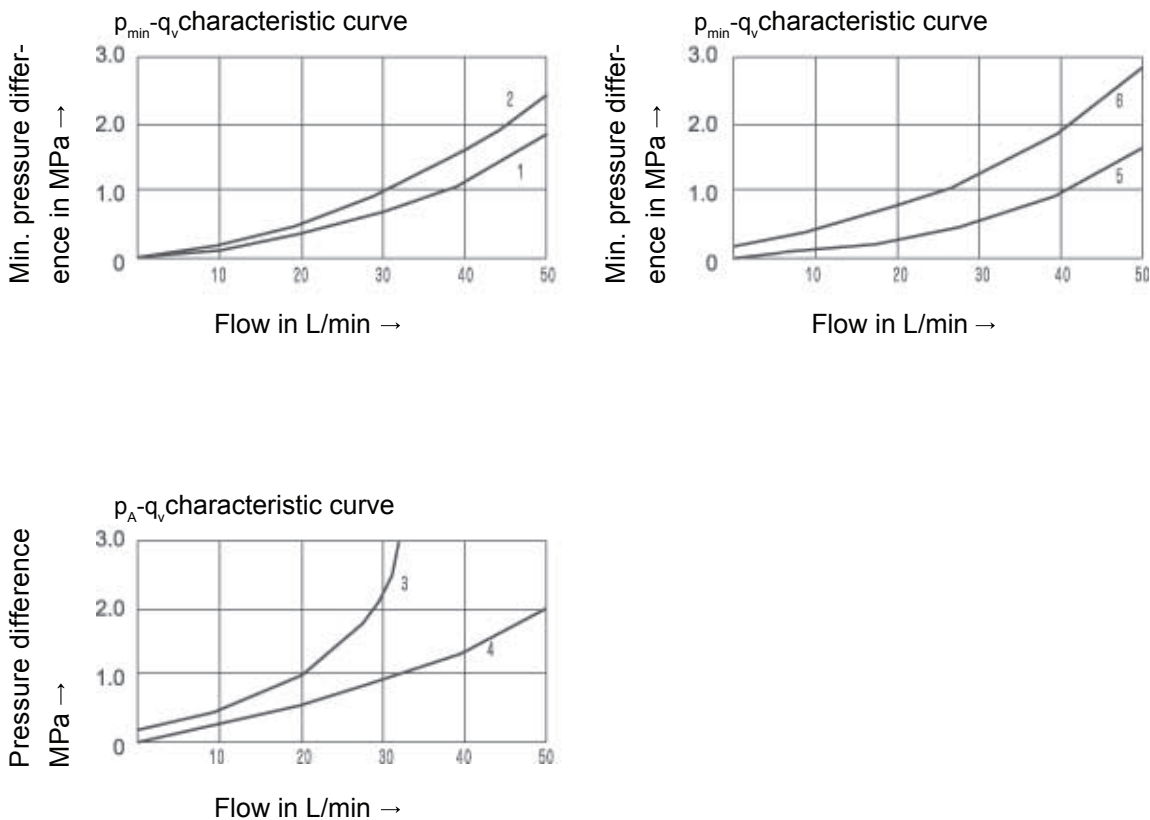

1. A to A1
2. A1 to TB (third. flow path)
3. A1 to A (flow via check valve only)
4. A1 to A (check valve and fully open control cross section)
5. P1 to TB
6. P1 to T(Y) (third. flow path)

The characteristic curves for the pressure relief function are valid for the outlet pressure = zero over the entire flow range!

Type ZDR6DP and ZDR6DB

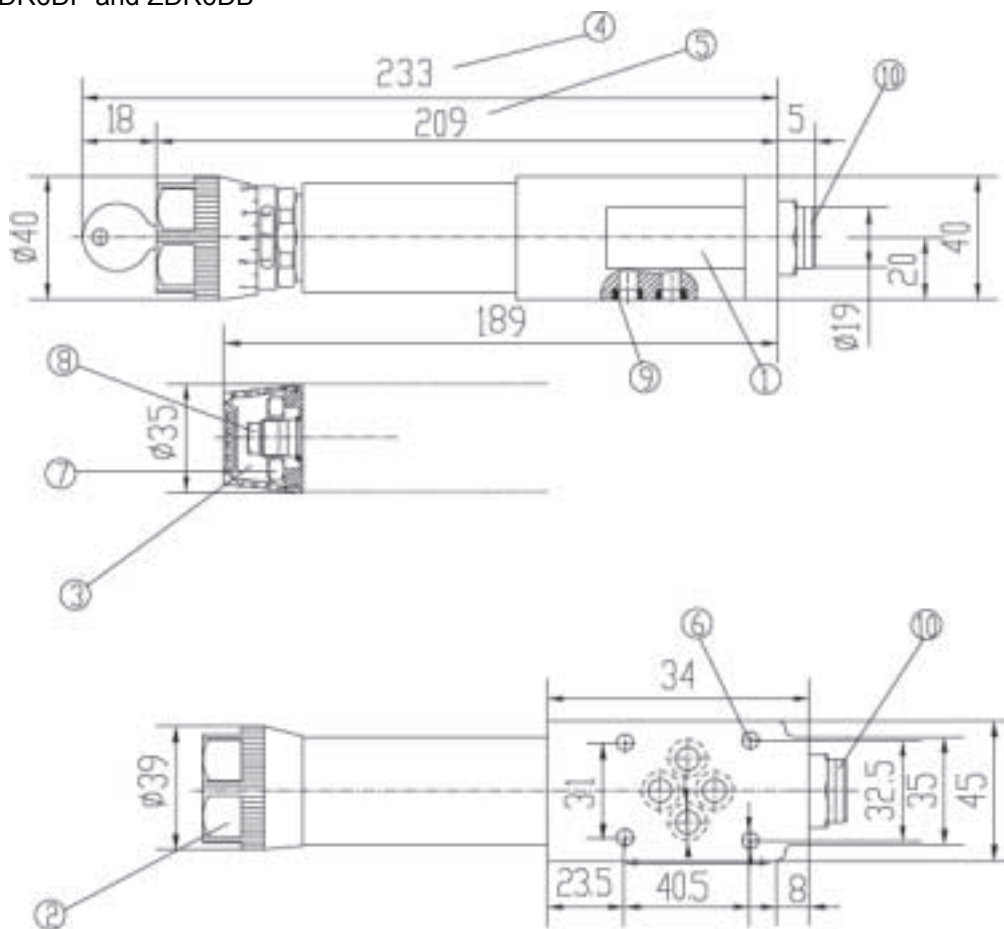

Type ZDR6DA

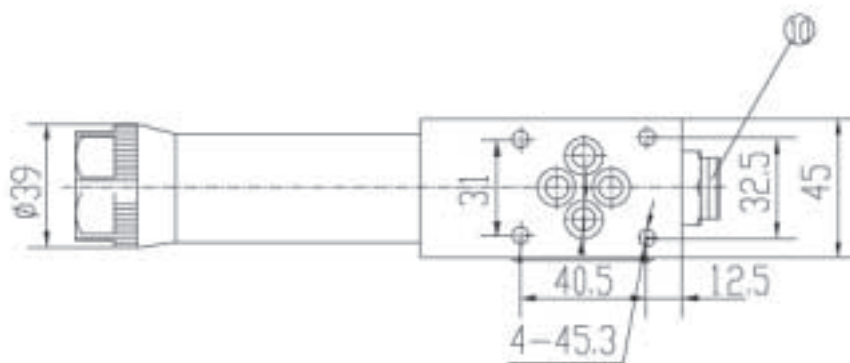

1. Nameplate
2. Adjustment1
3. Adjustment2
4. Adjustment3
5. Adjustment7
6. Valve fixing screw holes
7. Lock nut 24 A/F
8. Hexagon 10A/F
9. O-ring 9.25X1.78 for ports A2,B2,P2,T2(Y)
10. Pressure gauge port G1/4"; depth 12, internal hex. 6A/F



Required surface finish of mating piece

ANNOTATIONS :

HUADE AMÉRICA

CEP : 03162-020

RUA HIPÓDROMO 1445 – MOOCA, SÃO PAULO, SP, BRASIL

TEL : (11) 3186-5959

huade@huade.com.br

www.huade.com.br