

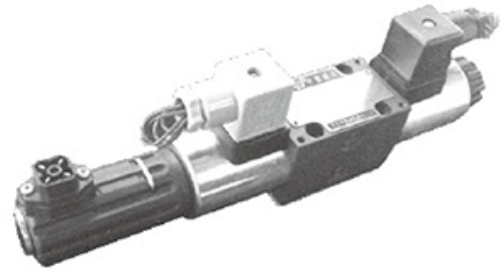

Catálogo de Productos

Proportional Directional Valves directly controlled, with electrical position feedback, type HD-4WRE(E)... 2x/

- Directly controlled proportional directional valve for the control of the direction and magnitude of a flow
- For subplate mounting
- Electrical position feedback
- Spring centred control spool
- Type 4WREE, integrated valve electronics with interface A1 or F1
- Actuation is by proportional solenoids with central thread and removable coil
- Valve and electronic control from one source



Function, section

The 4/2 and 4/3 proportional directional valves are directly controlled components of subplate mounting design. They are operated by proportional solenoids with central thread and removable coil. The solenoids are optionally controlled by either external control electronics (type WRE) or by integrated control electronics (type WREE).

Functional description:

With the solenoids (5 and 6), de-energised, the control spool (2) is held in the central position by the compression springs (3 and 4)

Direct operation of the control spool (2) by energising one of the proportional solenoids, e.g. control of solenoid "b" (6)

→ Movement of the control spool (2) to the left in proportion to the electrical input signal

→ Connection from P to A and B to T via orifice like cross-sections with progressive flow characteristics

De-energising of solenoid (6)

→ The control spool (2) is returned to the central position via the compression spring (3)

HD-4WRE...-2X/G24K4

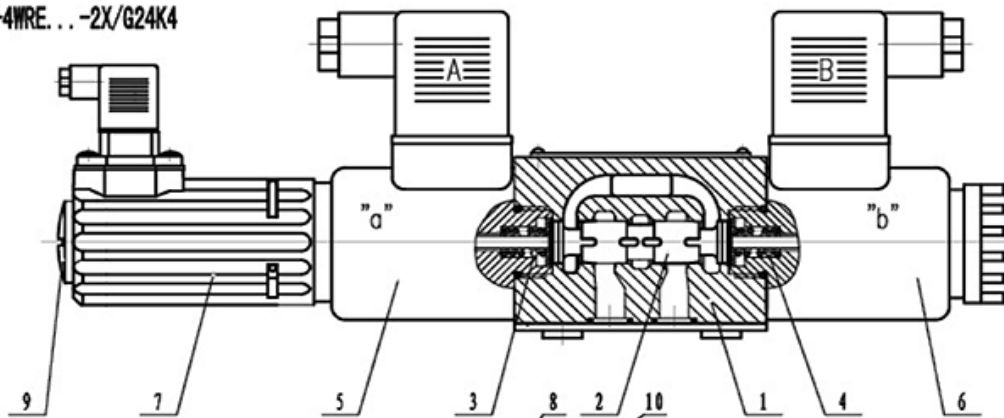

HD-4WREE...-2X/G24K4

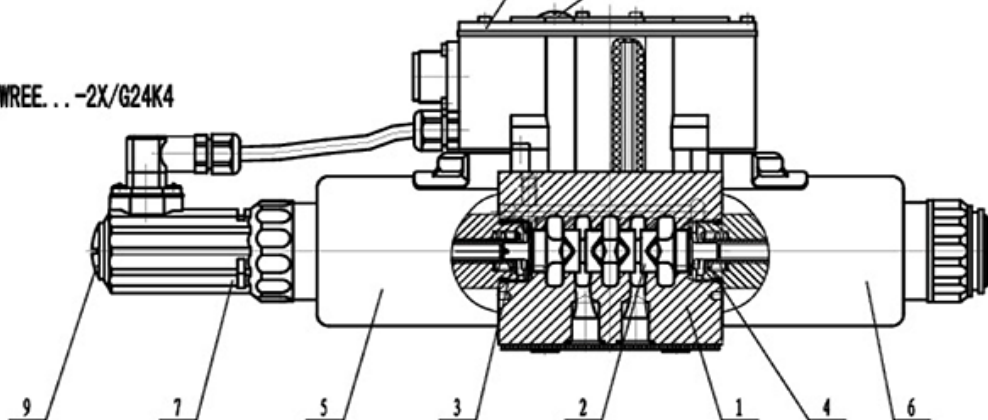

In the de-energised condition the spool (2) is held in a mechanical centre position by the solenoid return springs. This, for the spool symbol "V", does not relate to the hydraulic centre position! When the electrical valve closed loop control circuit is closed then the spool is positioned in the hydraulic centre position.

Design:

The valve basically consists of:

- Housing (1) with mounting face
- Control spool (2) with compression springs(3 and 4)
- Solenoids (5 and 6) with central thread
- Position transducer (7)
- Optional integrated control electronics (8)
- The mechanical zero point adjustment (9) is accessible via the Pg 13.5 and the electrical zero point is accessible via the Pg 7 (10) (type 4WREE)

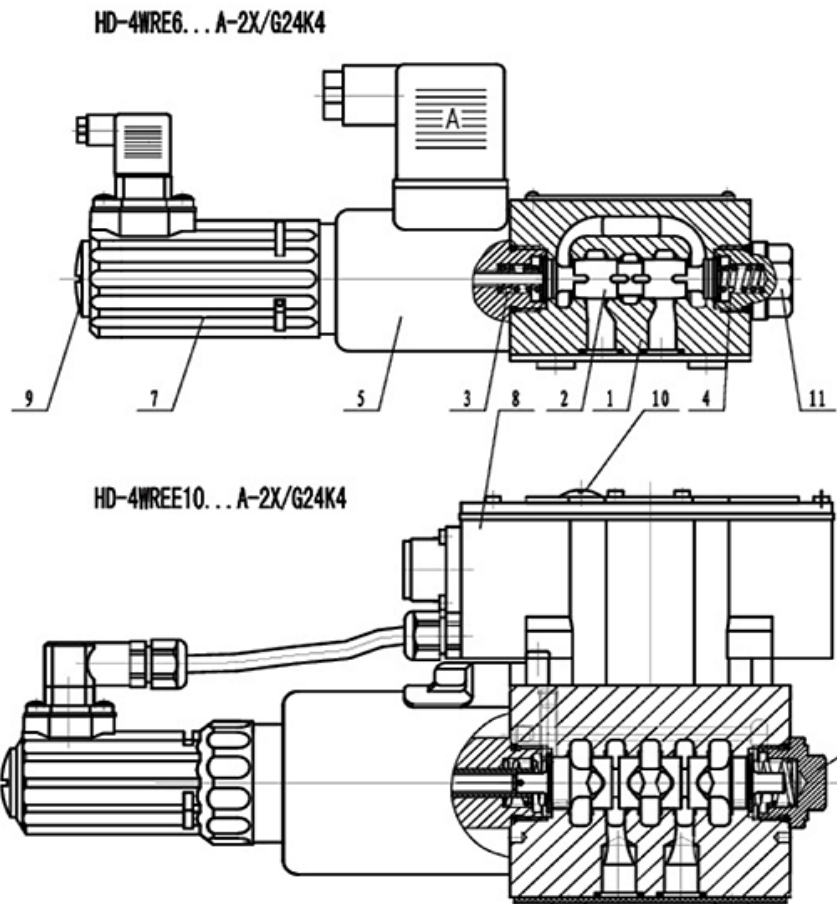

Symbols

| Without integrated control electronics | With integrated control electronics |
|---|--|
| <p>Type HD-4WRE...-2X/... 4/3 proportional directional valve</p> | <p>Type HD-4WREE...-2X/... 4/3 proportional directional valve</p> |
| <p>Type HD-4WRE...A- 2X/... 4/2 proportional directional valve</p> | <p>Type HD-4WREE...A- 2X/... 4/2 proportional directional valve</p> |

Ordering details

| | | | | |
|----|------|----|-----|---|
| HD | 4WRE | 2X | G24 | * |
|----|------|----|-----|---|

Techology of beijing huade hydraulic = HD

Without integrated control electronics = No code
With integrated control electronics =E

Nominal size 6 =6
Nominal size 10 =10

Symbols

With symbols E1- and W1-:
 $P \rightarrow A: q_{v \max}$ $B \rightarrow T: q_v / 2$
 $P \rightarrow B: q_v / 2$ $A \rightarrow T: q_{v \max}$

Note:
For spools W and WA there is, in the neutral position, a connection between A to T and B to T with approx. 3% of the relevant nominal cross-section.

Further details in clear text

No code = NBR seals
V = FKM seals

Interface A1 or F1 for WREE
A1 = Command value input ± 10 VDC
F1 = Command value input 4 to 20 mA

Electrical connection for WREE
K4 = With component plug(for WRA)
K31 = With component plug(for WRAE)

G24 = Power supply voltage 24 VDC

2X = Series 20 to 29
(20 to 29: unchanged installation and connection dimensions)

| Nominal flow at a valve pressure differential $\Delta p = 1$ MPa | | |
|--|-----|---------|
| NS6 | 08= | 8L/min |
| | 16= | 16L/min |
| | 32= | 32L/min |
| NS10 | 25= | 25L/min |
| | 50= | 50L/min |
| | 75= | 75L/min |

Electrical connection

Type 4WRE(for external control electronics)

Connections on the component plug

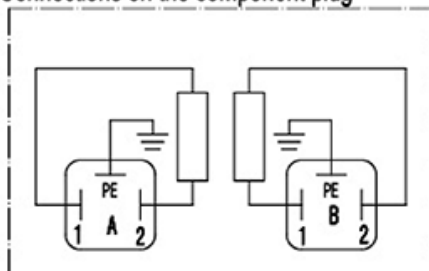

Connections on the plug-in connector

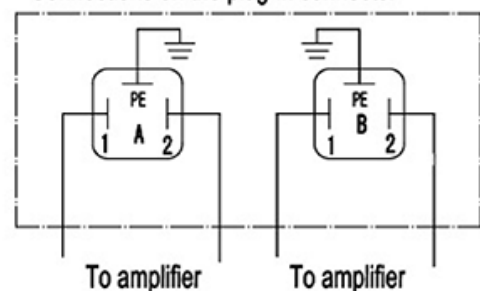

Technical data(for applications outside these parameters, please consult us!)

Hydraulic

| Size | | 6 | 10 |
|--|-------------|-------------------------------|----------|
| Operating pressure MPa | Ports A、P、B | 31.5 | 31.5 |
| | Port T | 21 | 21 |
| Nominal flow $Q_{V\text{nom}}$ at $\Delta P=1\text{MPa}$ (L/min) | | 8、16、32 | 25、50、75 |
| Max. permissible flow (L/min) | | 80 | 180 |
| Degree of contamination (μm) | | ≤ 20 (recommend 10) | |
| Hysteresis(%) | | ≤ 0.1 | |
| Reversal span (%) | | ≤ 0.05 | |
| Response sensitivity (%) | | ≤ 0.05 | |
| Pressure fluid | | Mineral oils, phosphate ester | |
| Viscosity range mm^2/S | | 20 to 380 | |
| Ambient temperature range (C°) | 4WRE | -20 to +70 | |
| | 4WREE | -20 to +50 | |
| Weight (Kg) | 4WRE | 2.2 | 6.3 |
| | 4WREE | 2.4 | 6.5 |

Electrical

| Electrical (integrated electronics) | | | |
|--|-----------------------------|--------------------|--------------------|
| Size | | 6 | 10 |
| Type of supply | | DC | DC |
| Nominal voltage (V) | | 24 | |
| Nominal current of solenoid (A) | | 2.5 | |
| Solenoid coil resistance (Ω) | Coil resistance at 20° C | 2.7 | 3.7 |
| | | 4.05 | 5.55 |
| Duty | | 100% | |
| Max. coil temperature (C°) | | to 150 | |
| Insulation to DIN40050 | | IP65 | |
| Technical data of associated amplifier | | | |
| Associated amplifier | 4WRE | HD-VT-VRPA2-. -1X/ | HD-VT-VRPA2-. -1X/ |
| | 4WREE | HD-VT-4WREE6-2X | HD-VT-4WREE10-2X |
| Supply voltage | Nominal voltage VDC | 24 | |
| | Lower limiting value V | 19.4 | |
| | Upper limiting value V | 35 | |
| Amplifier power consumption | I_{max} A | < 2 | |
| | Impulse current A | 3 | |

Integrated control electronics for type 4WREE

Plug-in connector to E DIN 43 563-BF6-3

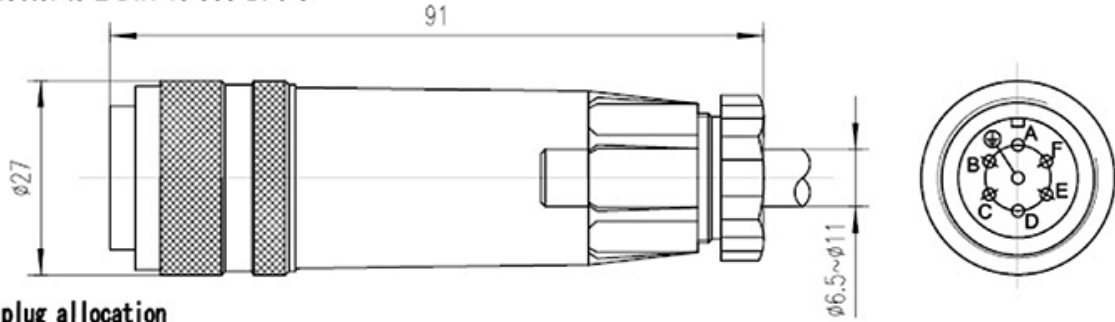

Component plug allocation

| | Contact | Allocation interface A1 | Allocation interface F1 |
|---------------------------------|---------|--|--|
| Supply voltage | A | 24 VDC ($u(t) = 19.4V$ to $35V$); $I_{max} = 2A$ | |
| | B | 0 V | |
| Ref. potential actual value | C | reference contact F; $R_e > 50k\Omega$ | reference contact F; $R_e < 10\Omega$ |
| Differential amplifier input | D | ± 10 V com. value; $R_e > 50 k\Omega$; | 4~20 mA com. value; $R_e > 100 \Omega$ |
| | E | ref. potential com. value | |
| Measurement output (act. value) | F | ± 10 V act. value, (limiting load 5 mA) | 4~20 mA act. value, load max. 300 Ω |
| | PE | Connected with cooling body and valve housing | |

Command value: A positive command value (or 12 to 20 mA) at D and the reference potential at E results in a flow from P to A and B to T. A negative command value (or 4 to 12 mA) at D and the reference potential at E results in a flow from P to B and A to T. For a valve with 1 solenoid on side a (e.g. spool variants EA and WA) a positive command value (or 4 ... 20 mA) at D and the reference potential at E results in a flow from P to B and A to T.

Actual value: A positive actual value (or 12 to 20 mA) at F and the reference potential at C results in a flow from P to A.

Connection cable: Recommended: - Up to 25 m cable length type LiYCY 7 x 0.75 mm²
 - Up to 50 m cable length type LiYCY 7 x 1.0 mm²

Outside diameter 6.5 to 11 mm

Only connect screen to PE on the supply side.

Block circuit diagram / connection allocation for the integrated valve electronics

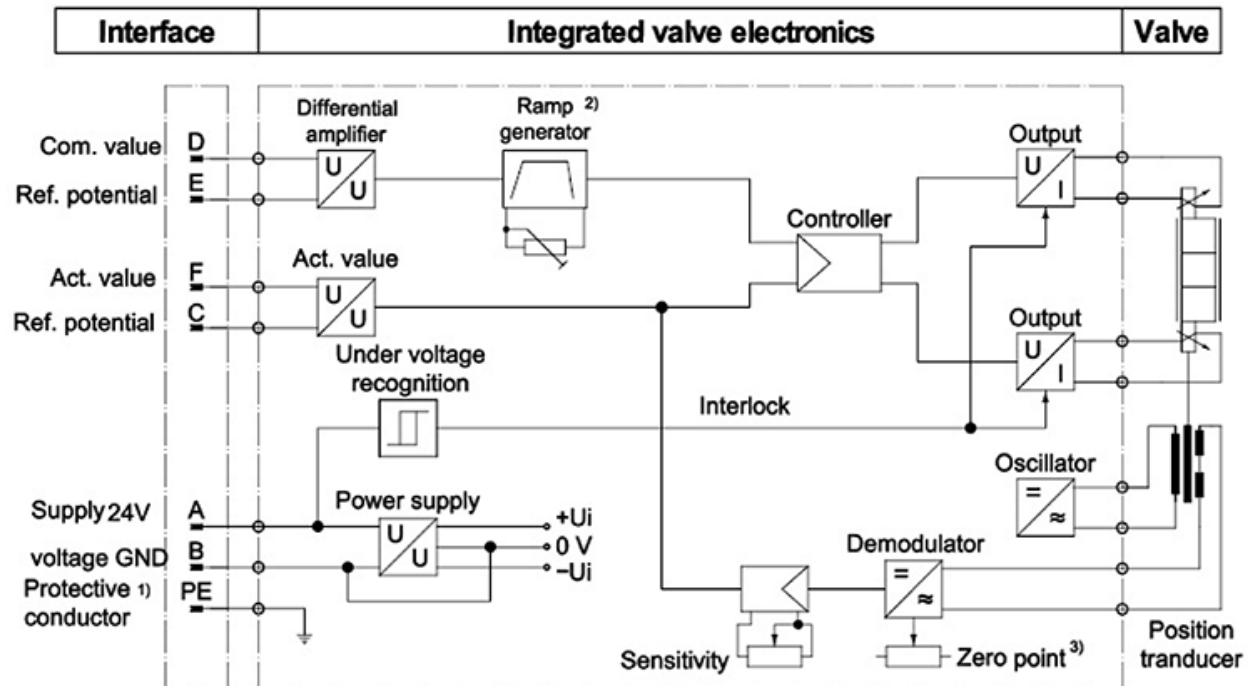

Integrated control electronics for type 4WREE

Note: Electrical signals processed by control electronics (e.g. actual value) must not be used for switching off safety-relevant machine functions!

- 1) Connection (PE) is connected to the cooling body and the valve housing;
- 2) Ramp is externally adjustable from 0 to 2.5 s; for T_{up} and T_{down}
- 3) Zero point is externally adjustable .

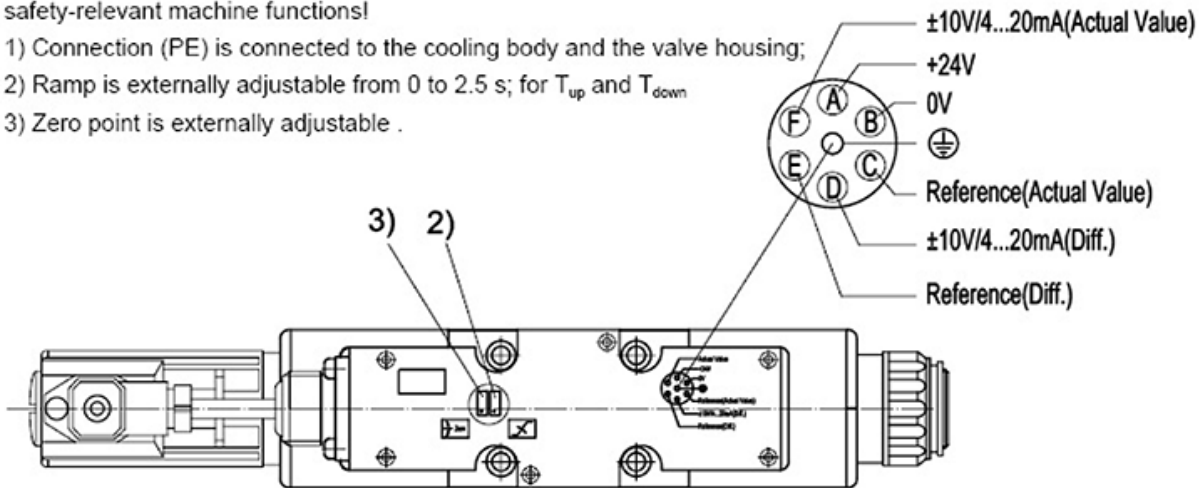

Characteristic curves for type 4WREE ($P=10\text{MPa}$, $v=36 \times 10^{-6} \text{ m}^2/\text{s}$, $t=50^\circ\text{C}$) NS 6 and 10

Pressure-signal-characteristic curves (V spool), $p_s = 10\text{MPa}$

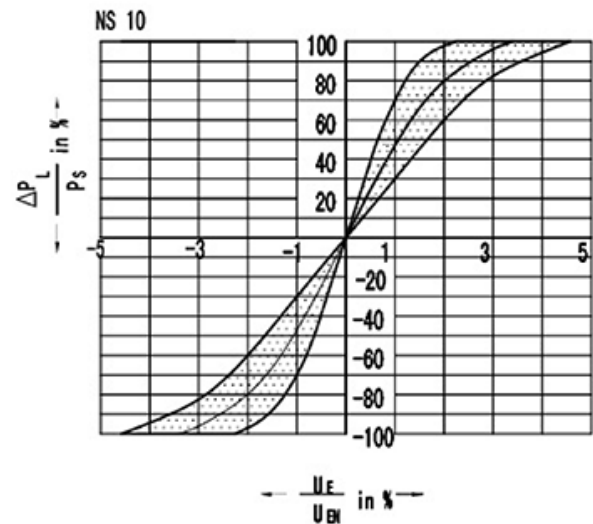
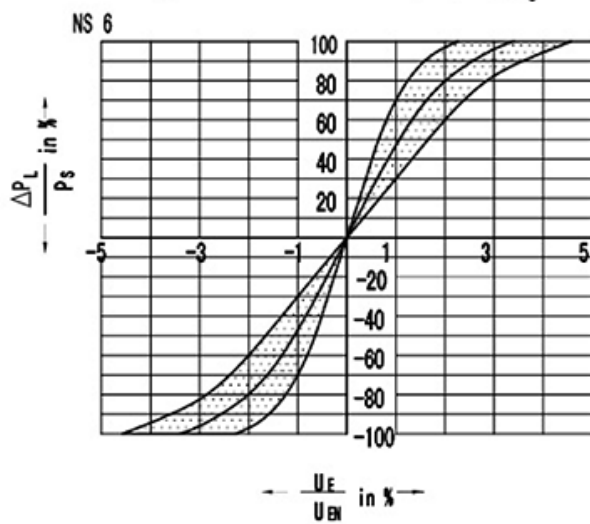

Leakage flow (with the spool in the central position)

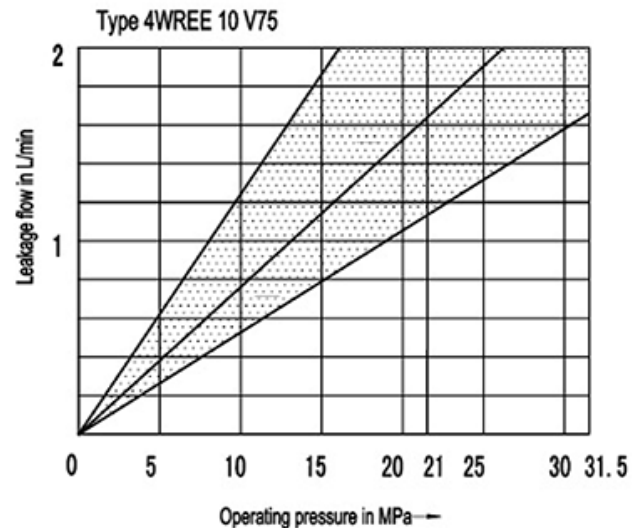
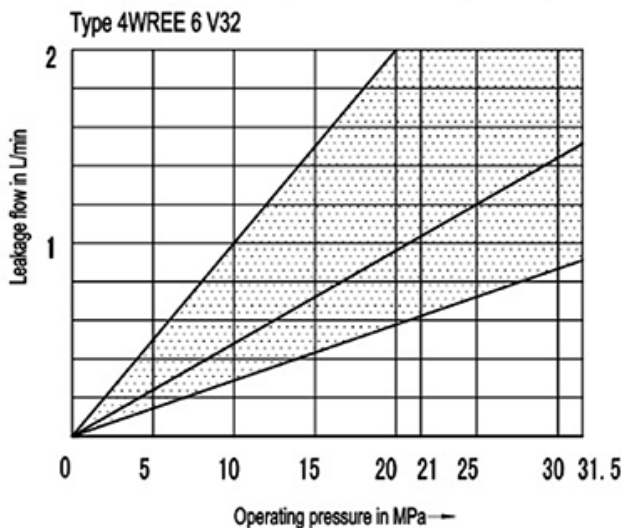

8 L/min nominal flow at a 1 MPa valve pressure differential

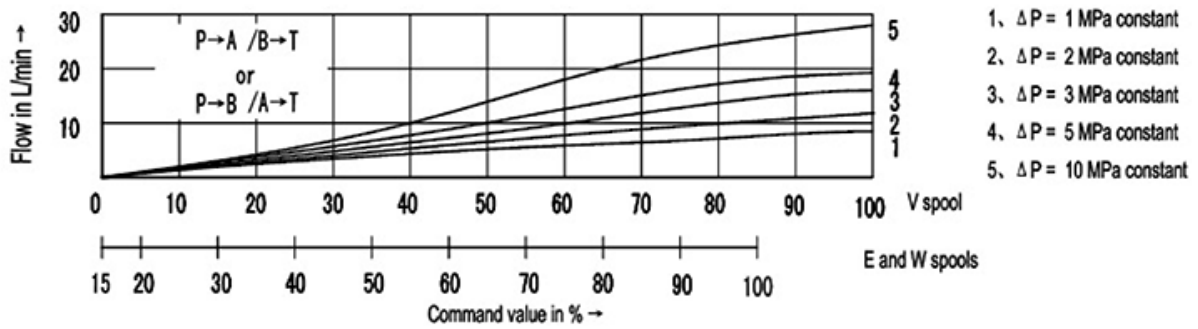

16 L/min nominal flow at a 1 MPa valve pressure differential

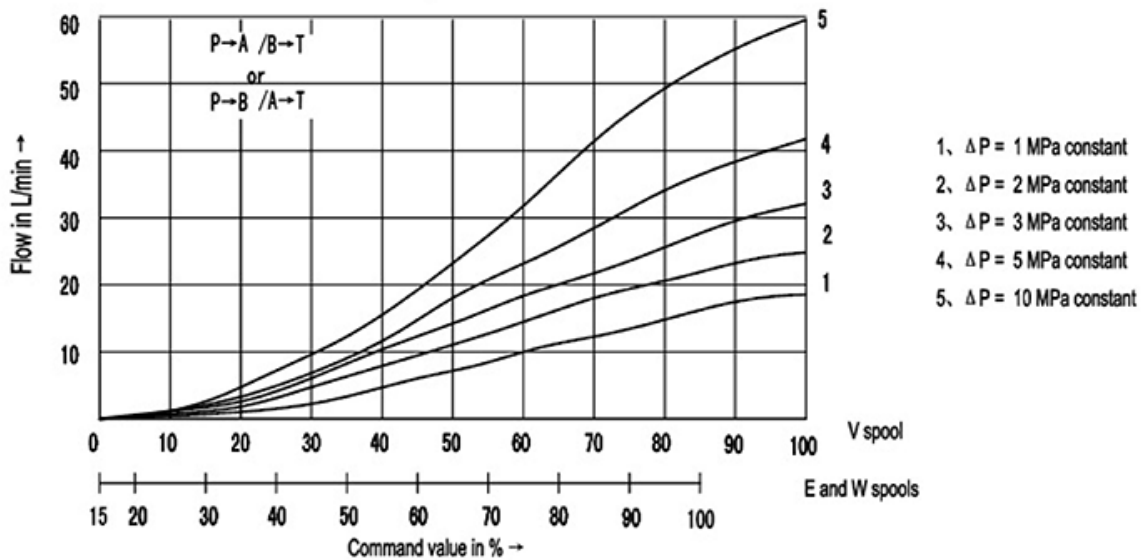

32 L/min nominal flow at a 1 MPa valve pressure differential

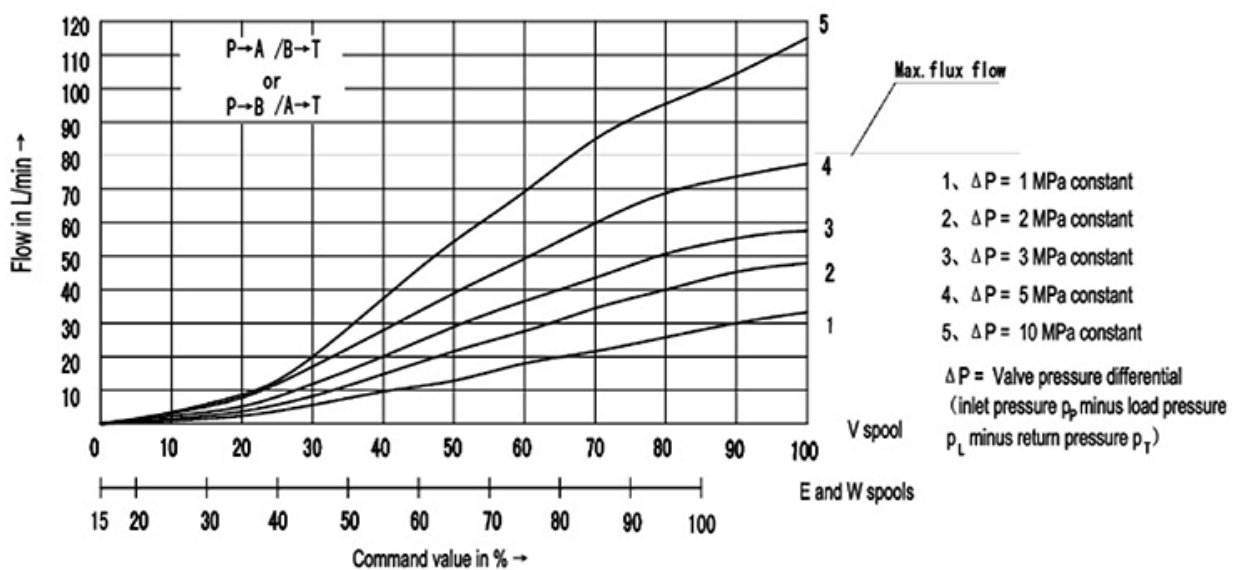

25 L/min nominal flow at a 1 MPa valve pressure differential

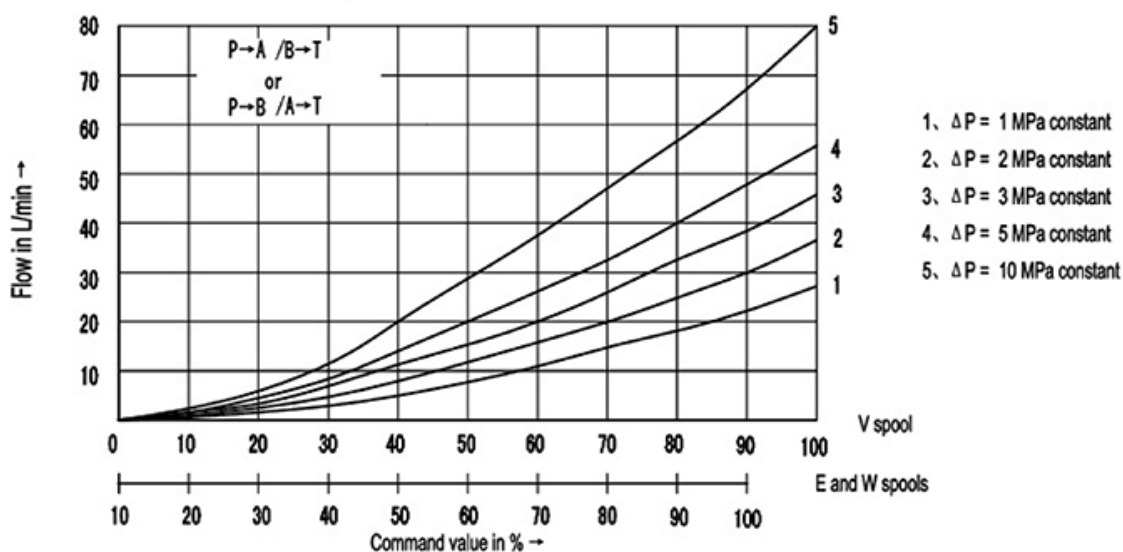

50 L/min nominal flow at a 1 MPa valve pressure differential

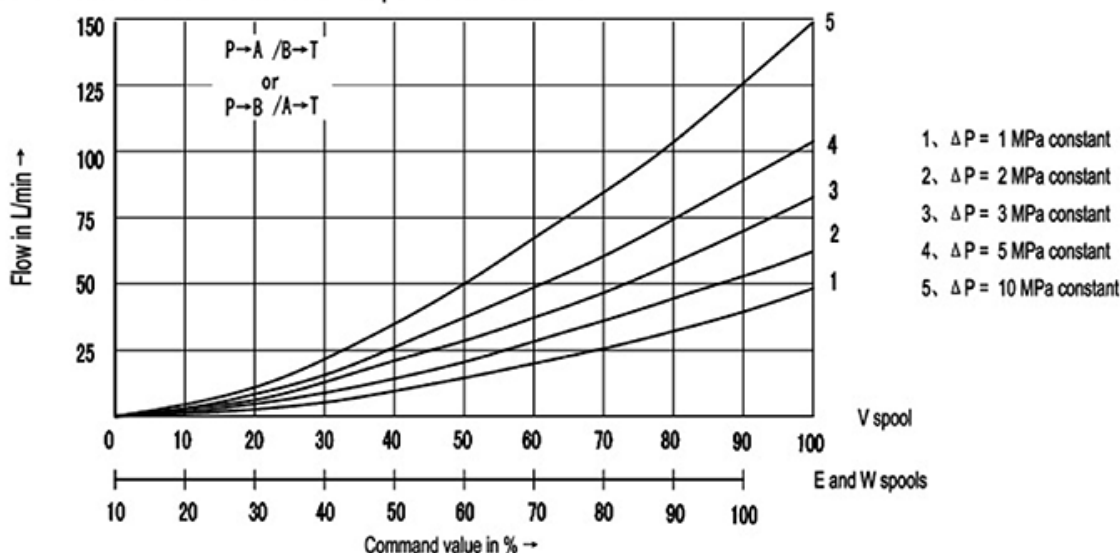

75 L/min nominal flow at a 1 MPa valve pressure differential

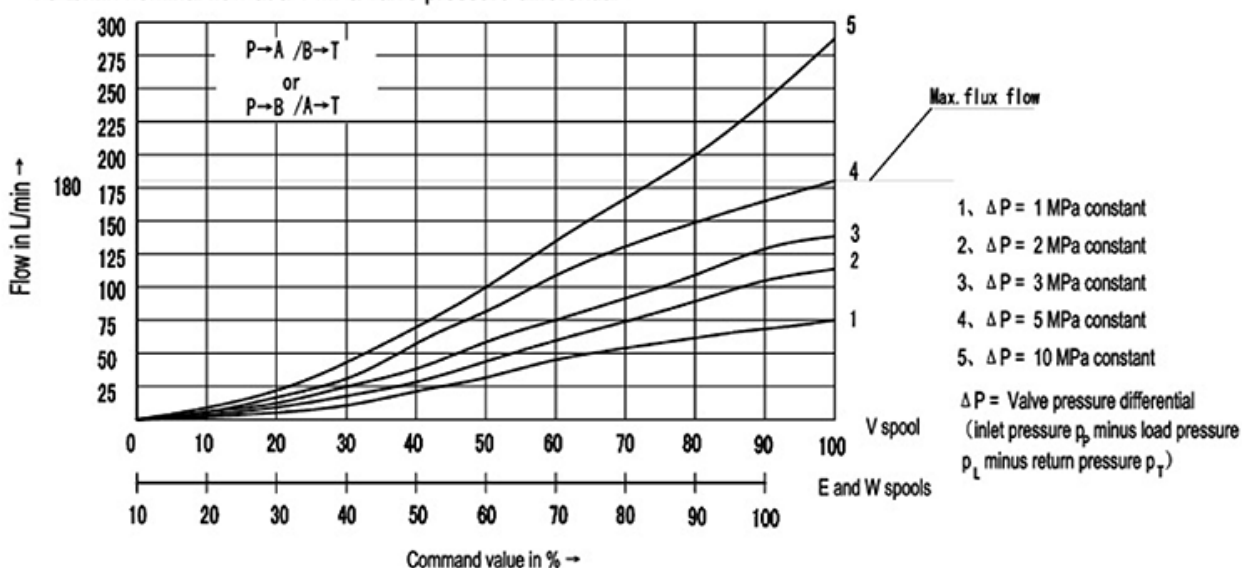

4/3 proportional directional valve
 Symbols "E"

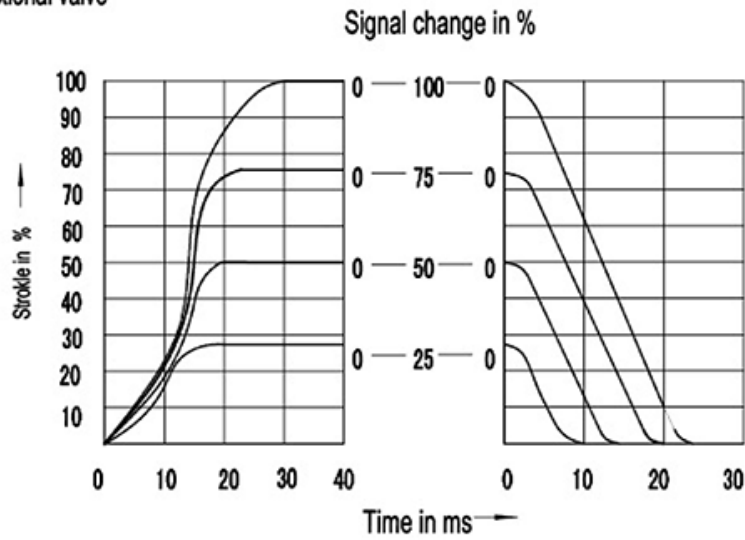

4/3 proportional directional valve
 Symbols "V"

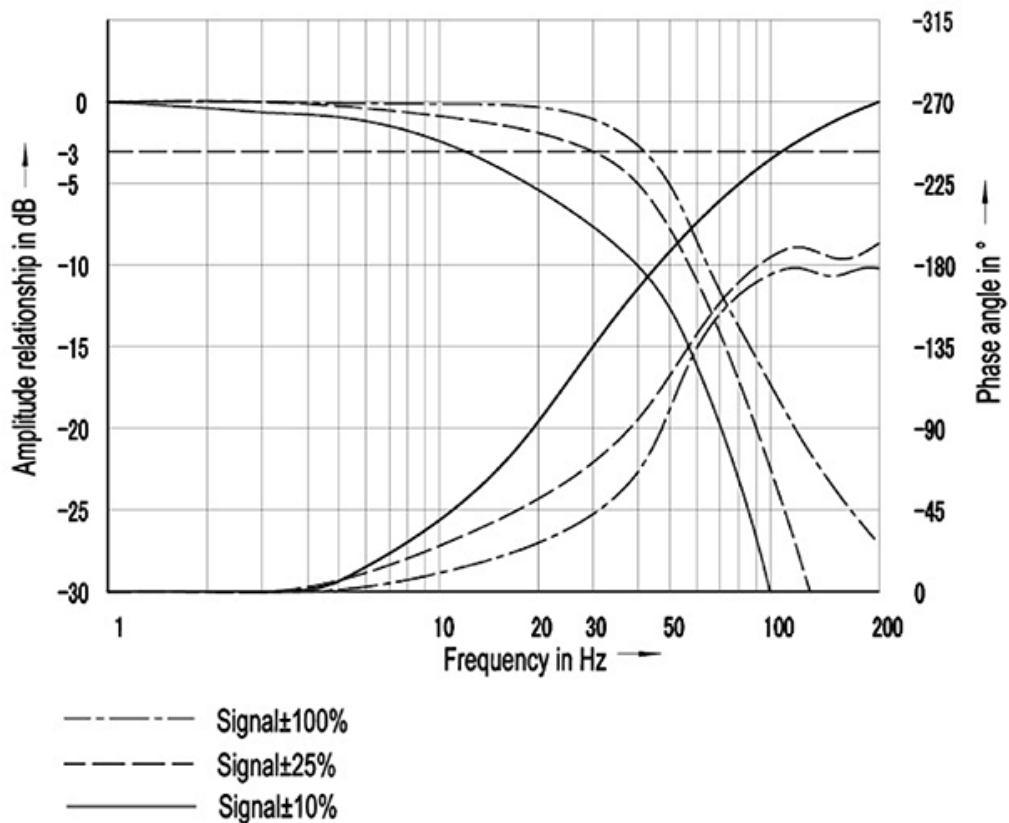

4/3 proportional directional valve
 Symbols "E"

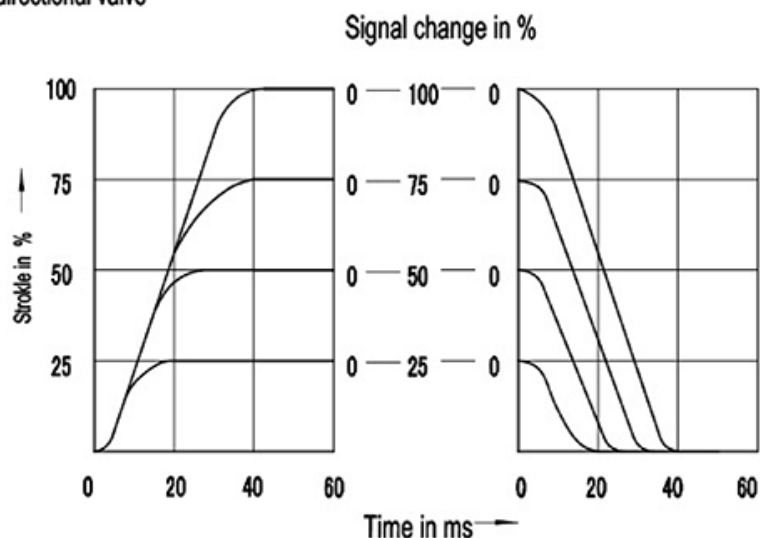

Frequency response characteristic curves for type 4WREE (P=10MPa, v=36×10⁻⁶ m²/s, t=50°C)

4/3 proportional directional valve
 Symbols "V"

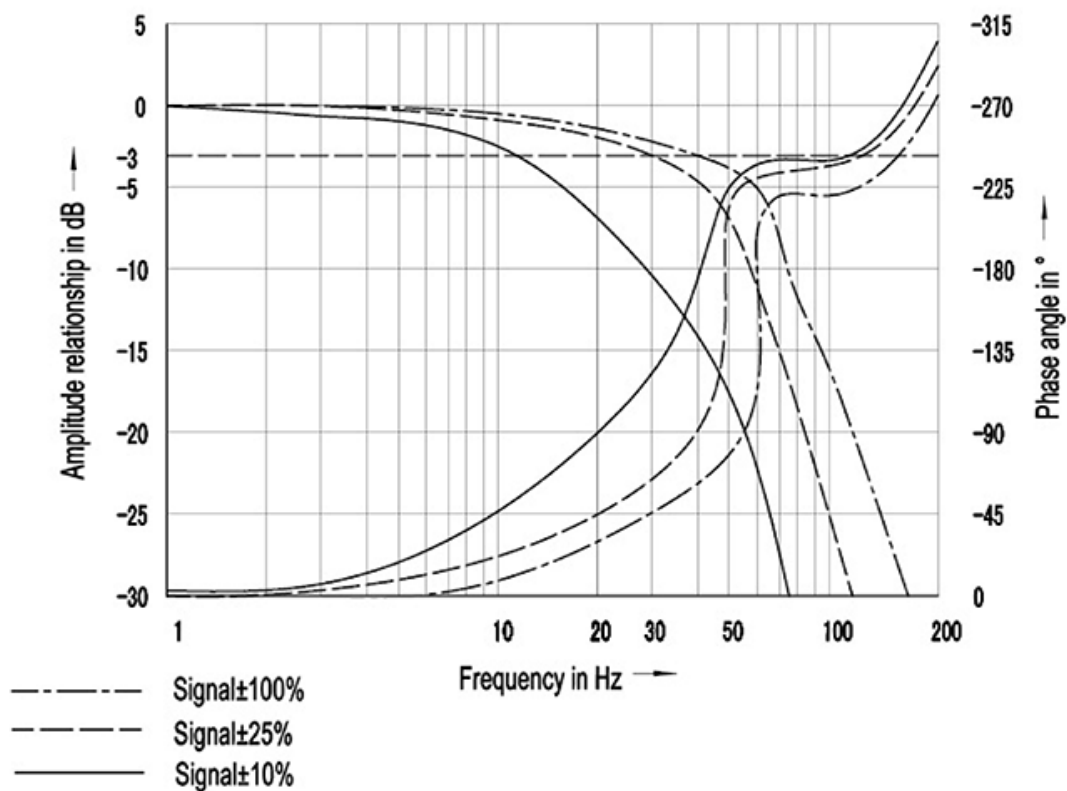

Flow load function at maximum valve opening
 Nominal flow 8L/min, 16L/min, 32L/min
 Symbols "V"

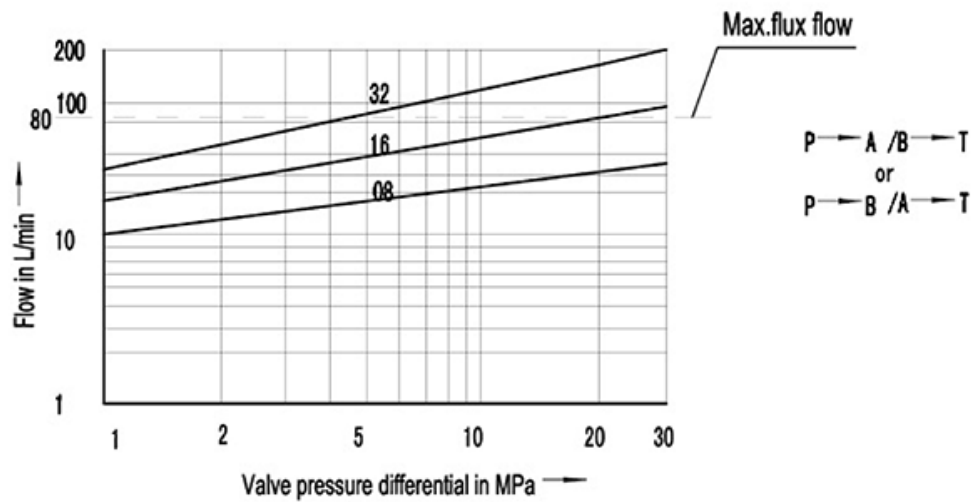

Warning : Please note the Max. flow 80L/min!

Flow load function at maximum valve opening
 Nominal flow 25 L/min, 50L/min, 75L/min
 Symbols "V"

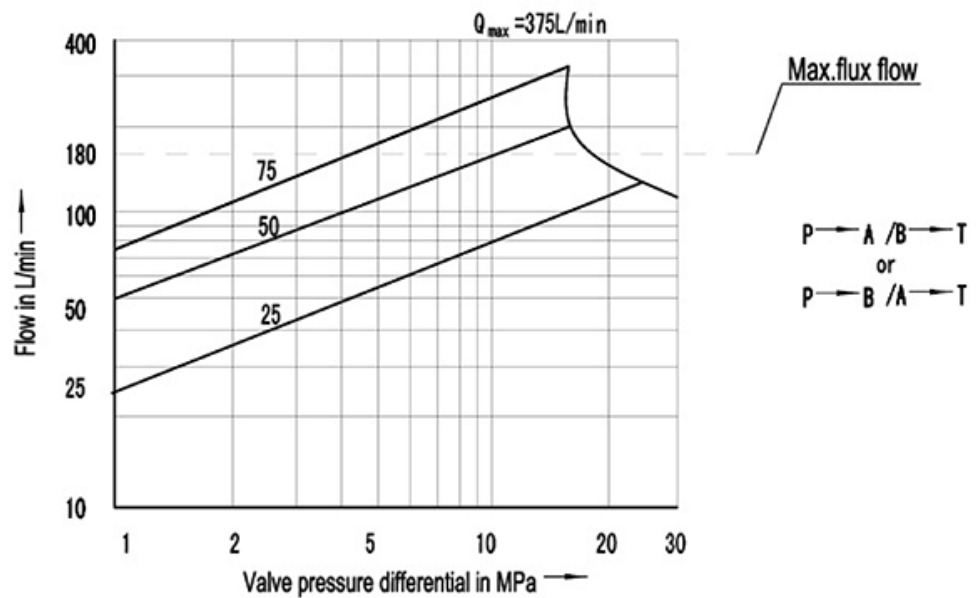

Warning : Please note the Max. flow 180L/min!

Type HD-4WRE6...-2X/

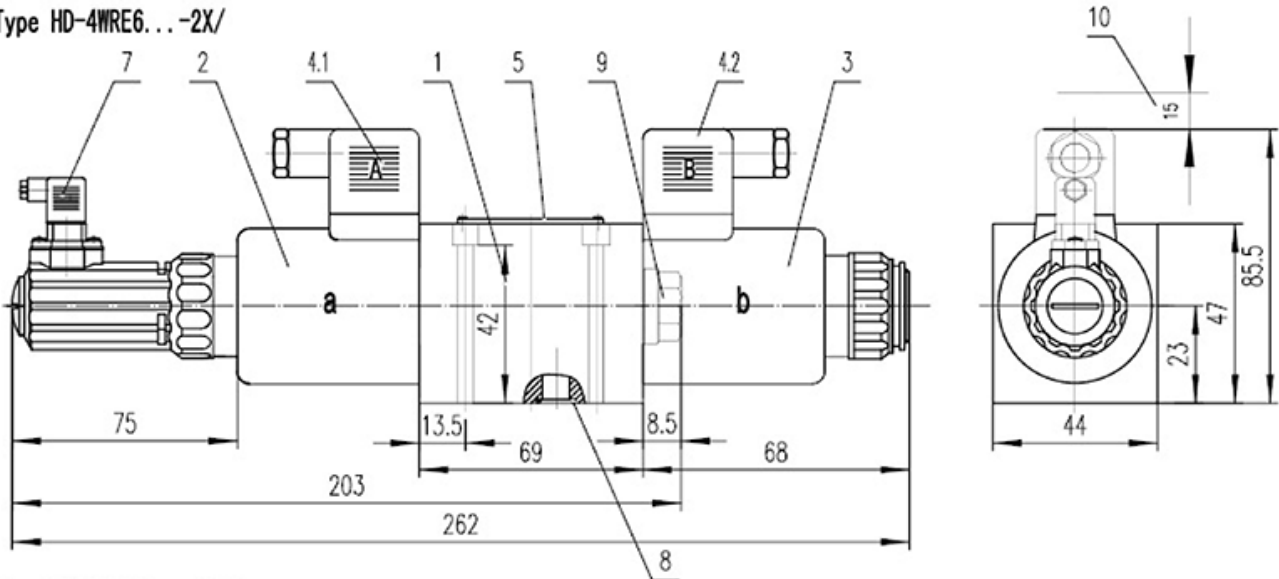

Type HD-4WREE6...-2X/

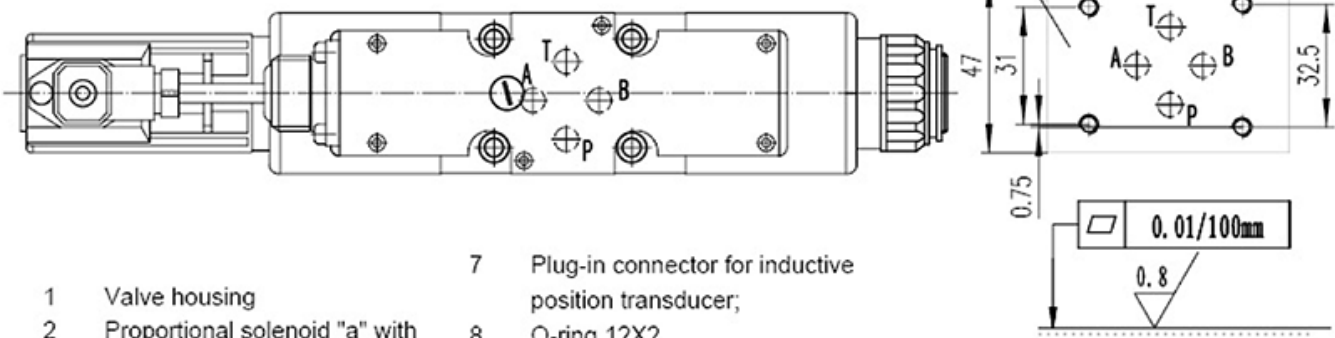
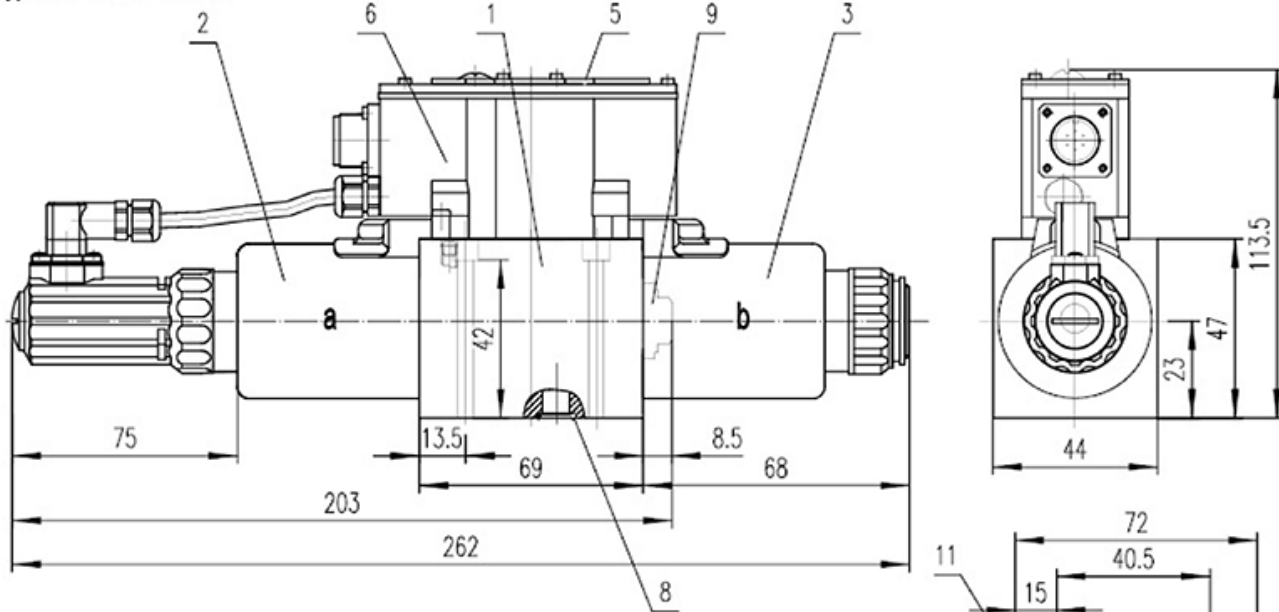

- 1 Valve housing
- 2 Proportional solenoid "a" with inductive position transducer
- 3 Proportional solenoid "b"
- 4.1 Plug-in connector "A"
- 4.2 Plug-in connector "B"
- 5 Nameplate
- 6 Integrated control electronics
- 7 Plug-in connector for inductive position transducer;
- 8 O-ring 12X2 (for ports P, A, B, TA, TB)
- 9 Plug for valves with one solenoid (2-switching positions), versions EA or WA
- 10 Space required to remove plug-in connector
- 11 Machined valve mounting surface and location of the connections

Subplates: G341/01(G 1/4")
 G342/01(G 3/8")
 G502/01(G 1/2")
 Valve fixing screws:
 4-M5X50 (GB/T70.1) M_A = 8.9Nm

ANNOTATIONS :

HUADE AMÉRICA

CEP : 03162-020

RUA HIPÓDROMO 1445 – MOOCA, SÃO PAULO, SP, BRASIL

TEL : (11) 3186-5959

huade@huade.com.br

www.huade.com.br