



Catálogo de Productos



BEIJING HUADE HYDRAULIC INDUSTRIAL GROUP CO.,LTD.	Direct operated pressure reducing valve sandwich plate,type ZDR 10 D...40B/			RE26584 /12.2004
	Size10	up to 21 MPa	up to 50L/min	Replaces: RE26584/05.2001

Features:

- Sandwich plate design
- Porting pattern to DIN 24 340, form A,ISO 4401 and CETOP-RP 121H
- Pressure reduction in ports A, B or p
- 3 adjustment elements:
 - Rotary knob
 - Hex. head screw with protective cap
 - Lockable rotary knob with scale
- 4 pressure ratings
- optional check valve



Functional, section

The pressure reducing valve type ZDR 10 D.. is a 3-way direct operated valve of sandwich plate design with a pressure relief function on the secondary side. It is used to reduce the system pressure.

The pressure reducing valve basically consists of the housing (1), the control spool (2), a compression spring (3),and the adjustment (4) as well as an optional check valve.

The secondary pressure is set by the pressure adjustment element (4).

Model "DA"

At rest, the valve is normally open, and fluid can flow unhindered from port A to port A1. The pressure in port A1 is at the same time via the control line (5) present at the spool area opposite to the compression spring (3). When the pressure in port A1 exceeds the pressure level set at the compression spring (3), the control spool (2) moves into the control position against the compression spring (3) and holds the set pressure in port A1 constant.

The control pressure and pilot oil are taken from port A1 via control line (5).

If the pressure in port A1 rises still further due to external forces, the control spool (2) is moved still further towards the compression spring (3).

This causes a flow path to be opened at port A1 via control land (6) on the control spool (2) and housing (1) to tank (port TB). Sufficient fluid then flows to tank to prevent any further rise in pressure.

The spring chamber (7) is always drained to tank externally via port TA .

A pressure gauge connection (8) permits the secondary pressure at the valve to be monitored.

It is only possible to fit a check valve for free flow in ports A1 to A in version "DA".

Models "DP" and "DB"

In model "DP", the pressure is reduced in port P1. The control pressure and the pilot oil is taken internally from port P1.

In model "DB", the pressure in port P1 is reduced, and the pilot oil taken from port B.

Attention!

When the directional valve is in the switched position P to A, pressure in port B must not exceed the set secondary pressure. Otherwise, pressure in port A will be reduced.

If used without a directional valve, TA and TB must be interconnected (e.g. in the cover plate).

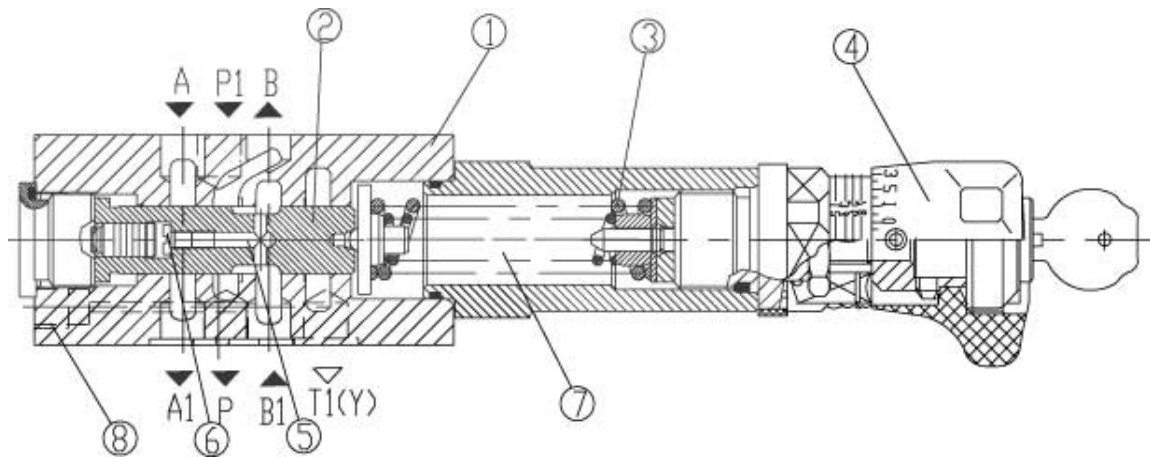

ZDR10D...40B/...YM

Symbols

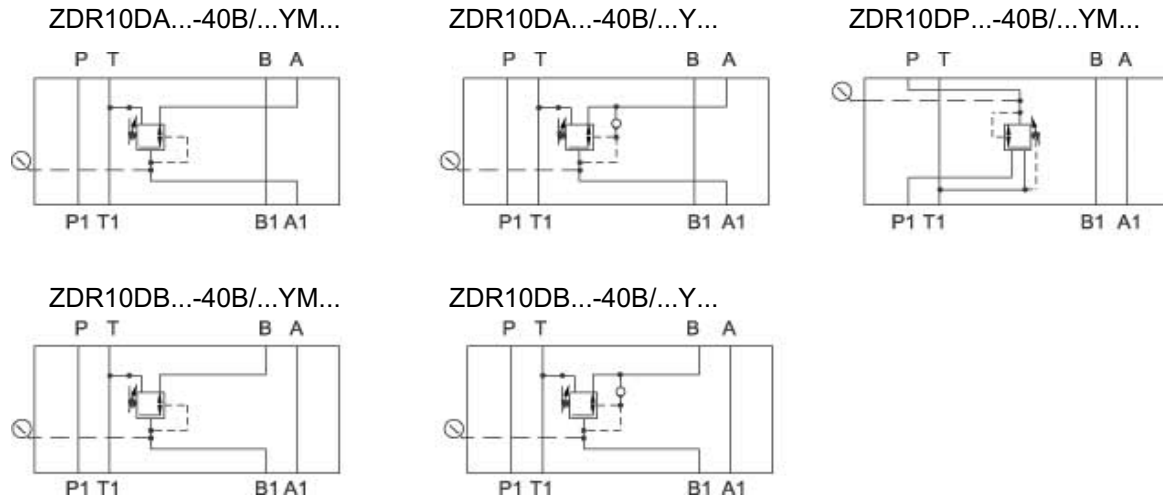

Ordering details

Z DR 10 D - 40 B / Y *

Sandwich plate design = Z

Pressure reducing valve = DR

Size 10 = 10

Direct operated = D

Pressure reduction in port A = A
 Pressure reduction in port B = B
 Pressure reduction in port P = P

Setting elements
 Rotary knob = 1
 Hex. head screw with protective cap = 2
 Lockable rotary knob with scale = 3

Series 40 to 49 = 40
 (40 to 49 = unchanged installation and connection dimensions)

Further details in clear text

No code. = mineral oils
 V = phosphate ester

No code. = with check valve
 (only possible for pressure reduction in port A,B)
 M = without check valve

Y = Pilot oil feed internal, drain external

25 = max. secondary pressure 2.5 MPa
 75 = max. secondary pressure 7.5 MPa
 150 = max. secondary pressure 15 MPa
 210 = max. secondary pressure 21 MPa

B = Technology of Beijing Huade Hydraulic

Technical data (For applications outside these parameters, please consult us!)

Weight	(Kg)	approx. 2.8
Pressure fluid		Mineral oil (for NBR seal) or phosphate ester (for FPM seal)
Pressure fluid - temperature range	(°C)	-30 to +80
Viscosity range	(mm ² /s)	10 to 800
Degree of fluid contamination		recommend a filter with a minimum retention rate of $\beta_{10} \geq 75$
Max. operating pressure Port P	(MPa)	up to 31.5
Secondary pressure (output)	(MPa)	up to 21
Back pressure Ports T (Y)	(MPa)	up to 15
Max. flow	(L/min)	50

Characteristic curves (measured at $v = 41\text{mm}^2/\text{s}$ and $t=50^\circ\text{C}$)

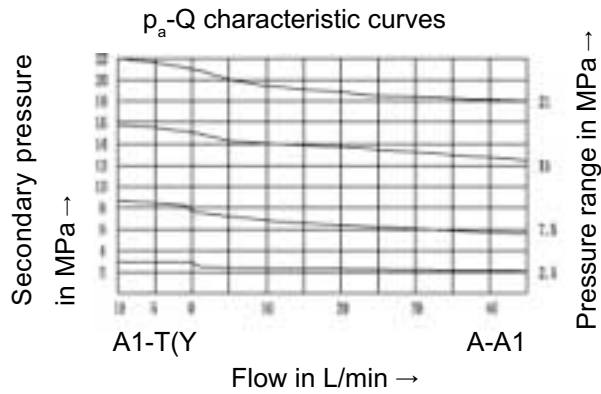

P_{amin} -Q characteristic curve, Maximum secondary pressure 2.5MPa. Min. adjusting pressure is related to A-A1, B-B1 and P-P1. When $P=3\text{MPa}$, flow of ports A1 and P1 are 20L/min. If pressure rises above $P=3.4\text{MPa}$, flow=0.

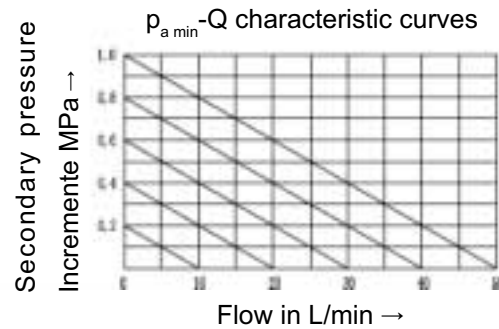
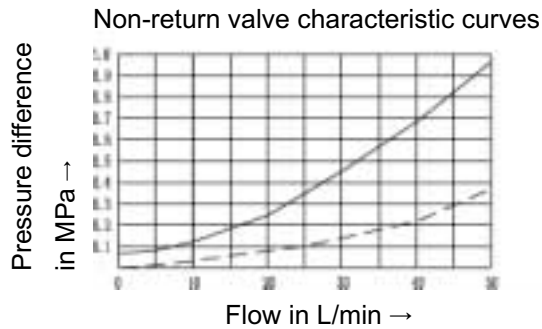

Unit dimensions: type ZDR10DB

(Dimensions in mm)

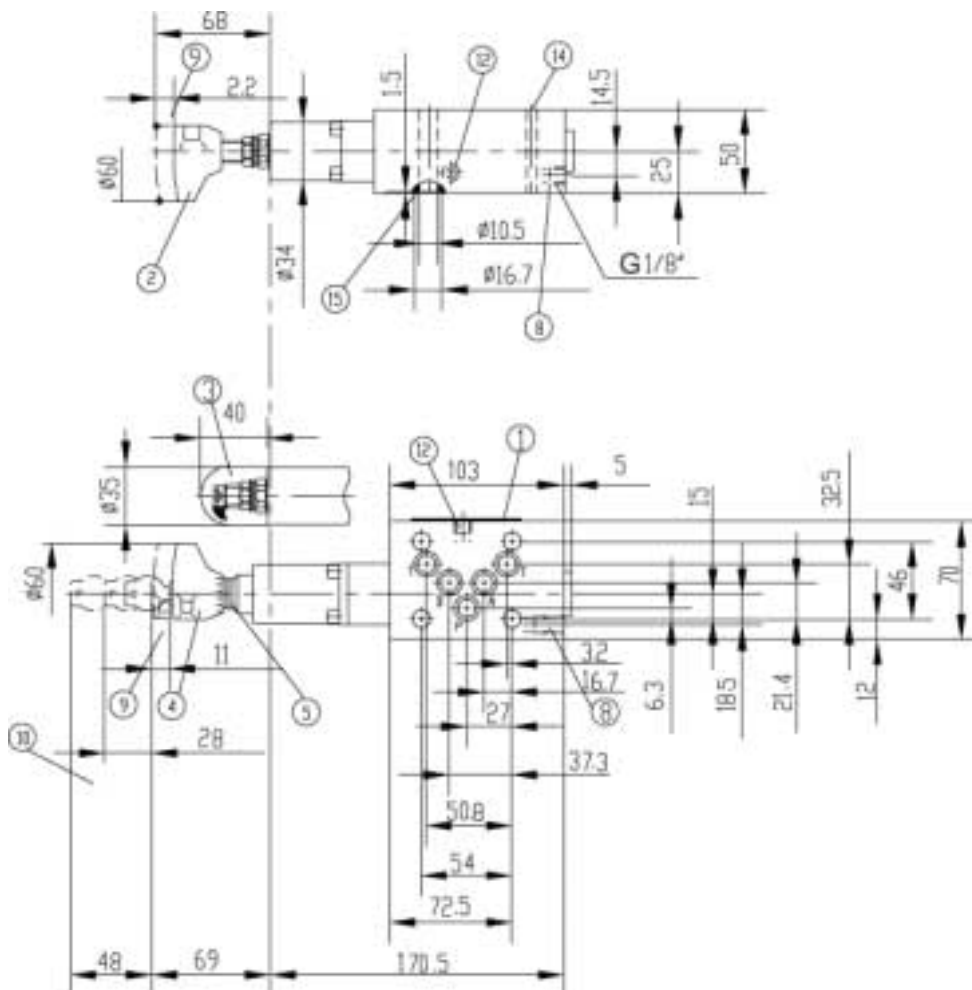

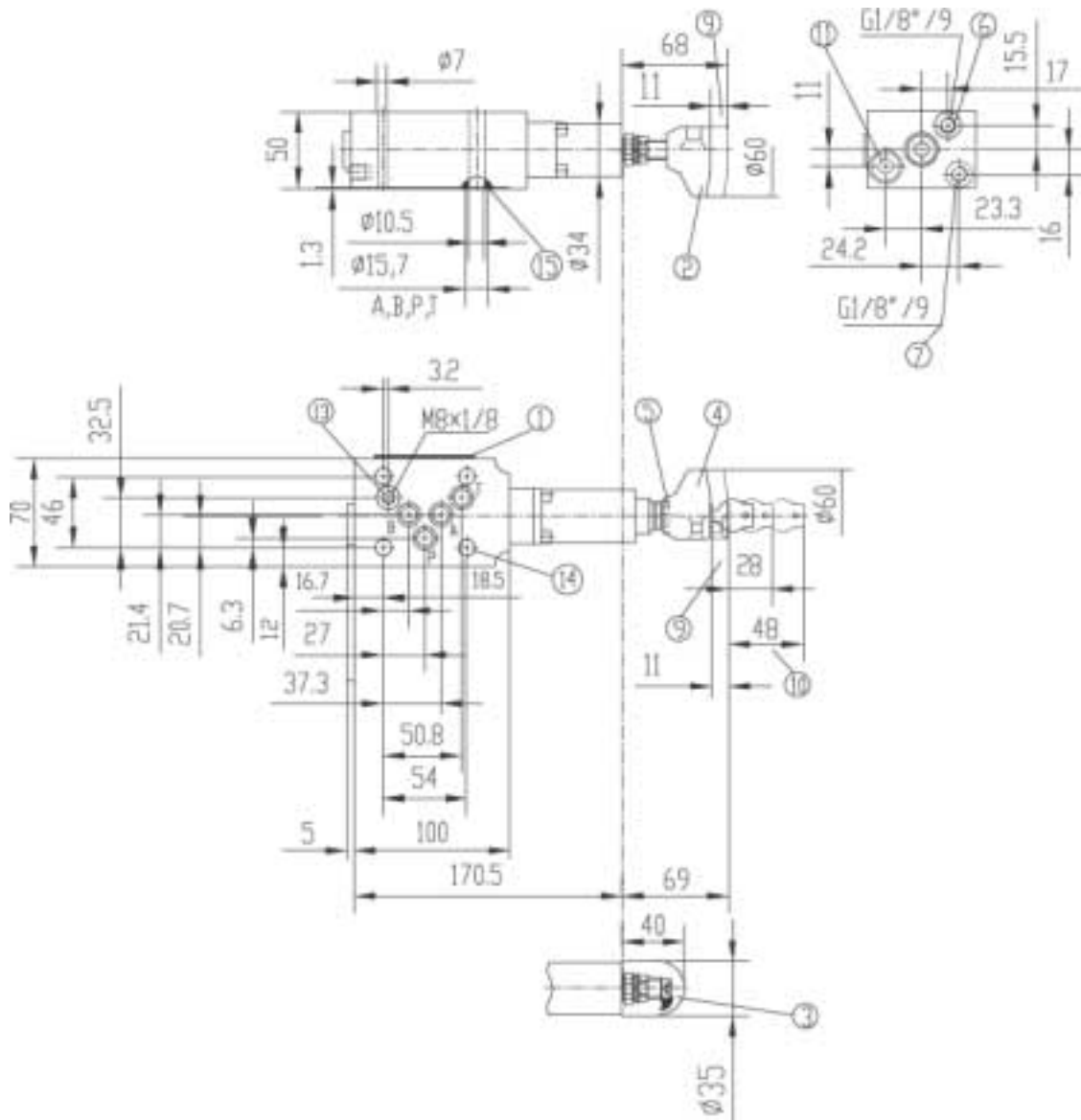

- | | |
|---|--|
| 1. Nameplate | 11. Optional check valve for ZDR10DA |
| 2. Adjustment1 | 12. Optional check valve for ZDR10DB |
| 3. Adjustment2 | 13. Maximum secondary pressure is 2.5MPa, stem on this hole; When 7.5MPa, 15MPa and 21MPa, use as a leakage hole; This hole can use as chamber "T", at the same time needn't use chamber "T" (right), must unload spool. Opposite hole with O-ring drilling a hole, use as a leakage hole. |
| 4. Adjustment3 | |
| 5. Adjusting scale set | |
| 6. A pressure gauge connection for ZDR 10DP | |
| 7. A pressure gauge connection for ZDR 10DA | |
| 8. A pressure gauge connection for ZDR 10DB | 14. Fixed screw hole |
| 9. Max. distance of adjustment | 15. O-ring 12X2 for ports A, B, P, T |
| 10. Space required to remove key | |

Required surface finish of mating piece



